



TECHNICAL DESCRIPTION MX-3



Technical data

	fresh milk	topping
mains connection:	230 V, 50 Hz	230 V, 50 Hz
power consumption:	3500 W	2300 W
recommended daily output:	approx. 160 cups	approx. 160 cups
mains protection:	1 x 16 A	1 x 16 A
boiler capacity (coffee):	1.0 l, 2000 W	1.0 l, 2000 W
boiler capacity (steam):	1.0 l, 1200 W	-
number of cappuccinatore:	1	-
number of grinders:	2	1
number of bean hoppers:	2	1
bean hopper capacity:	0.65 kg each	0.65 kg
number of mixers:	1	2
number of instant containers:	1	2
instant container capacity:	1.25 kg (chocolate)	1.25 kg chocolate or 1 kg instant powder
dimensions [B x H x T]:	325 mm x 717 mm x 560 mm	325 mm x 717 mm x 560 mm
net weight:	approx. 41 kg	approx. 41 kg
gross weight:	approx. 50 kg	approx. 50 kg
max. height beverage outlet:	150 mm	150 mm

Provided by customer

- ♦ water supply: 3/8" (max 1.5 m far from the device)
- ♦ water drain (option): 40–50 mm diameter, with stretch tap, open funnel, suitable for hot water
- ♦ mains connection: Schuko outlet
- ♦ water filter system: recommended for a carbonate hardness > 5 ppm

Equipment

- ♦ one brewing group
- ♦ steam and hot water output
- ♦ fixed fresh water supply
- ♦ 8 illuminated product selection buttons
- ♦ graphic display
- ♦ automatic rinsing and cleaning programme
- ♦ colour: black

Options

- ♦ water tank
- ♦ water drain
- ♦ telemetry
- ♦ milk pump
- ♦ grounds slide
- ♦ connection to cash systems via CKI (Coffema Cash Interface)
- ♦ coin changer, coin checking device

CE Conformity



This product is in conformity with the essential European directives.

TECHNICAL DESCRIPTION

MX-3



Dimensions

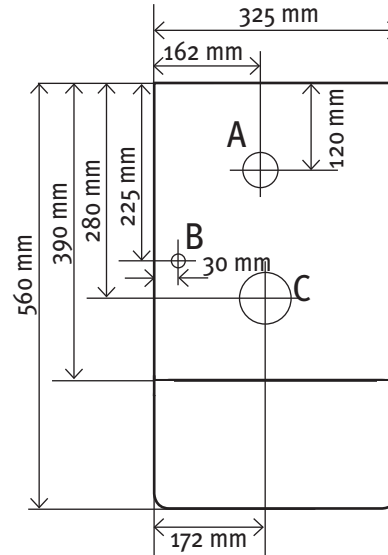

- A: hole for supply cables
approx. 70 mm diametre
- B: hole for milk suction tube
approx. 10 mm
- C: hole for ground slide (option)
approx. 80 mm diametre

NOTE

When installing the machine, observe a distance of 100 mm minimum to walls and objects.

Distribution scheme

